

# LAPORAN PENELITIAN

## Factors Affecting Fraud Prevention And Its Implication To The Quality Of Financial Statements



Disusun Oleh:

Ketua Peneliti

Monika Budiman, S.E., M.Ak

NIDN: 0319049401

Anggota:

1. Dr. Choirul Anwar, AK., MBA., MAFIS

NIDN : 0004106907

2. Dr. Sudjono, M.Acc

NIDN : 0311025901

SEKOLAH TINGGI ILMU EKONOMI Y.A.I

JAKARTA

2021

## HALAMAN PENGESAHAN

|    |                               |   |   |
|----|-------------------------------|---|---|
| 1. | Judul Penelitian              | : | Factors Affecting Fraud Prevention And Its Implication To The Quality Of Financial Statements                                     |
| 2. | Bidang Ilmu Penelitian        | : | Akuntansi   |
| 3. | Ketua Peneliti                | : |   |
|    | a. Nama Lengkap dan Gelar     | : | Monika Budiman, SE., M.Ak   |
|    | b. Jenis Kelamin              | : | Perempuan   |
|    | c. NIDN                       | : | 0319049401  |
|    | d. Golongan/Pangkat           | : | - / -   |
|    | e. Program Studi              | : | Akuntansi S1  |
|    | f. Email                      | : | <a href="mailto:monikabudiman@stie-yai.ac.id">monikabudiman@stie-yai.ac.id</a>  |
| 4. | Anggota Tim Peneliti          | : | 1. Dr. Choirul Anwar, AK., MBA., MAFIS<br>(NIDN:0004106907)   |
|    |                               |   | 2. Dr. Sudjono, M.Acc (NIDN:0311025901)   |
| 5. | Waktu Penelitian              | : | September 2020 - Februari 2021  |
| 6. | Biaya Penelitian              | : |   |
|    | a. Jumlah                     | : | Rp. 1.500.000   |
|    | b. Sumber                     | : | STIE Y.A.I  |
| 7. | Publikasi                     | : | Jurnal Ilmiah   |
|    | a. Nama Jurnal                | : | Journal of Applied Finance & Accounting (JAFA)  |
|    | b. Volume                     | : | 8, Edisi 1  |
|    | c. Halaman                    | : | 1 – 25  |
|    | d. Tahun dan Bulan Penerbitan | : | Juni 2021   |
|    | e. ISSN                       | : | 2746-6019   |
|    | f. Scope Jurnal               | : | Nasional  |
|    | g. Akreditasi Jurnal          | : | -   |
|    | h. Alamat Website             | : | <a href="https://journal.binus.ac.id/index.php/JAFA/issue/view/362">https://journal.binus.ac.id/index.php/JAFA/issue/view/362</a> |
|    | i. URL artikel                | : | <a href="https://journal.binus.ac.id/index.php/JAFA/issue/view/362">https://journal.binus.ac.id/index.php/JAFA/issue/view/362</a> |
|    | j. Alamat DOI artikel         | : | <a href="https://journal.binus.ac.id/index.php/JAFA/issue/view/362">https://journal.binus.ac.id/index.php/JAFA/issue/view/362</a> |

Jakarta, 30 Juni 2021

Mengetahui,  
Ketua Lembaga Penelitian dan  
Pengabdian Kepada Masyarakat STIE Y.A.I

  
(Ida Musdafiah Ibrahim, SE., M.M)  
NIDN: 03230570001

Ketua Peneliti

  
(Monika Budiman, SE., M.Ak)  
NIDN: 0319049401

Menyetujui  
Ketua STIE Y.A.I

  
(Dr. Reschiwati, SE, MM, Ak. CA.)  
NIDN : 0309116603

## DAFTAR ISI

|                                    |    |
|------------------------------------|----|
| HALAMAN PENGESAHAN .....           | 1  |
| DAFTAR ISI.....                    | 2  |
| DAFTAR LAMPIRAN .....              | 3  |
| KATA PENGANTAR.....                | 4  |
| DOKUMEN PUBLIKASI PENELITIAN ..... | 5  |
| LAMPIRAN .....                     | 30 |

## DAFTAR LAMPIRAN

|   |    |
|---|----|
| Lampiran 1 Surat Tugas Penelitian Jurnal..... | 30 |
|---|----|

## KATA PENGANTAR

Puji syukur kepada Tuhan Yang maha Esa yang telah melimpahkan rahmat dan karunia-Nya sehingga peneliti dapat menyelesaikan laporan penelitian ini dengan baik. Penelitian ini dimaksud untuk menjadi bahan kajian bidang akuntansi dan *auditing* di Indonesia dan menambah wawasan dan informasi mengenai pencegahan *fraud* dan dampaknya pada laporan keuangan, oleh karena itu penelitian ini berjudul: *Factors Affecting Fraud Prevention And Its Implication To The Quality Of Financial Statements*.

Kegiatan ini dapat terlaksana atas bantuan dan dukungan berbagai pihak. Oleh karena itu peneliti mengucapkan banyak terimakasih kepada Ketua STIE Y.A.I, Kaprodi Akuntansi, dan Ketua LPPM, yang telah memberikan izin untuk melaksanakan penelitian ini juga rekan-rekan dosen serta karyawan STIE Y.A.I, atas segala dukungan yang diberikan sehingga penelitian ini dapat terlaksana dengan baik.

Peneliti menyadari bahwa Laporan Penelitian ini masih jauh dari sempurna, oleh karena itu kritik dan saran yang bersifat konstruktif dari pembaca sangat diharapkan guna penyempurnaan Laporan Penelitian ini. Akhirnya, peneliti mengharapkan agar Laporan Penelitian ini dapat memenuhi fungsinya sebagai substansi ilmu pengetahuan baik di kalangan dosen, mahasiswa maupun masyarakat pada umumnya. Demikian laporan ini peneliti susun sebagai bagian dari pertanggungjawaban hasil penelitian yang telah dilaksanakan.

Jakarta, 30 Juni 2022

Peneliti,

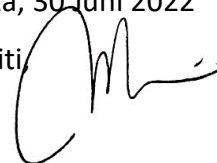

Monika Budiman, SE., M.Ak

## FACTORS AFFECTING FRAUD PREVENTION AND ITS IMPLICATION TO THE QUALITY OF FINANCIAL STATEMENTS

Monika Budiman<sup>1</sup>; Choirul Anwar<sup>2</sup>; Sudjono<sup>3</sup>

<sup>1,2,3</sup>Sekolah Tinggi Ilmu Ekonomi Y.A.I, Jakarta, Indonesia, 10440,

<sup>1</sup>[monika.budiman@stie-yai.ac.id](mailto:monika.budiman@stie-yai.ac.id); <sup>2</sup>[anwar\\_choirul@yahoo.com](mailto:anwar_choirul@yahoo.com); <sup>3</sup>[sudjonoidris@gmail.com](mailto:sudjonoidris@gmail.com)

### ABSTRACT

*The study aims to determine the effect of internal control, internal audit, risk-based audit, audit committee, and whistleblowing system on fraud prevention and its implications to the quality of financial statements. The sample consisted of 7 companies from 12 populations of chemical sub-sector companies and 5 companies from 10 populations of pharmaceutical sub-sector companies listed on the Indonesia Stock Exchange in 2018. Data were collected using questionnaires with 154 respondents. The analysis technique using Structural Equation Modeling (SEM) and processed with Lisrel 8.8. The results indicate that, partially, internal control, internal audit, risk-based audit, and audit committee have a positive and significant effect on fraud prevention, while the whistleblowing system partially has a negative and insignificant effect. However, simultaneously, the direct effect of internal control, internal audit, risk-based audit, audit committee, and whistleblowing system on fraud prevention have a positive and significant effect. The results also show partially internal control, internal audit, whistleblowing system, and fraud prevention have a positive and-significant effect on the quality of financial statements while risk-based audit has a positive but not significant effect and the audit committee has a negative and insignificant effect on the quality of financial statements. However, simultaneously, the indirect effect of internal control, internal audit, risk-based audit, audit committee, whistleblowing system on the quality of financial statements through fraud prevention have a positive and significant effect.*

**Keywords:** Internal Control, Internal Audit, Risk-Based Audit, Audit Committee, Whistleblowing System, Fraud prevention, Quality of Financial Statement

### INTRODUCTION

The quality of a company's financial statements is judged by how much information presented can be useful for users, and its systematic preparation is based on a conceptual framework and basic accounting principles. The higher the quality of the financial statements, the better the company's information will be. Nowadays, many financial statements are manipulated to gain various advantages and harm other parties because they do not reflect the actual results. This phenomenon is one of the economic crimes that cause a decrease in the quality of financial statements. It can be seen that the development of accounting in the era of globalization brings many benefits to society, both material and non-material. The number of companies in the manufacturing industry has contributed greatly to the country. Based on the report from Caturini & Hidayat at Kontan (2018), *Badan Pusat Statistik Indonesia* notes that the industrial sector continues to provide

the largest contribution to the national Gross Domestic Product (GDP) with achievement of 20.16% in 2017. The non-oil and gas processing industry grew by 5.14% in the fourth quarter of 2017, higher than the same period in 2016 that reached around 3.91%. In addition, in 2017, the export value of the processing industry was US\$ 125 billion. This figure provides the highest contribution of up to 76% of the total export value of Indonesia, which reached US\$ 168.73 billion. This proves that the industry is still the largest contributor to the national GDP. On the other hand, this condition has resulted in increasingly fierce business competition. In the end, seeking the maximum profit with the least possible sacrifice will result in unfair business competition and disadvantage many parties.

The most notorious financial statements frauds are Enron, WorldCom, and Xerox. Enron recorded a profit of 600 million US dollars even though the company suffered a loss. This fraud involved KAP Arthur Andersen, who became Enron's external auditor. This case caused a

decline in investor confidence in the reliability of financial statements and resulted in 4,000 Enron employees losing their current jobs. In Indonesia, the largest fraud was committed by PT Kimia Farma, which manipulated their financial statements in 2001. It was found that there was an overstatement in the income statement of Rp 32.7 billion, which is 2.3% of sales and 24.7% of net income. Rezaee (2005) said that financial statement fraud is a serious threat to market participants' confidence in published audited financial statements. Moreover, Rabiū & Mansor (2015) also stated that fraud should not be taken lightly as it causes serious problems such as attempts to conceal, fake, and manipulate for illegal use.

One of the fraud prevention factors is internal control. According to COSO (2013), the definition of internal control is a process carried out by the board of directors, management, and other personnel of a company that is designed to provide reasonable and adequate assurance regarding the achievement of operating, reporting, and compliance objectives. The result of Pramudityo's (2017) research found that internal control has a positive effect on the quality of financial statements, but Widyaningtias (2014) found that internal control has a negative and insignificant effect on the quality of financial statements.

To support internal control, an internal audit is required. Petrascu & Tleanu (2014) stated that all entities need an internal audit for business efficiency in the sense of good management of its patrimony, of reducing costs while maximizing profit, and of achieving medium and long-term objectives, furthermore, this activity is seen as a perspective of the benefits it entails in countering fraud and especially in increasing future added value. According to Maliawan, Sujana, and Diatmika (2017) internal audit has an effect on fraud prevention. Internal audit affects both fraud prevention efforts and the quality of financial statements. This is in accordance with Pramudityo's research (2017), which found the effect of the role of internal audit on the quality of financial statements. However, different results presented by Widyaningtias (2014) that internal audit has no effect on the quality of financial statements.

In line with current business developments, it has been able to bring a paradigm shift in the application of auditing from a control approach to a risk-based audit approach. Rozali and Mohammad (2015) stated that a risk-based audit is an audit based on the results of identification and analysis of material risks which have the potential to hinder business strategies and objectives, so that audit planning, inspection and reporting are measurable. The increasing implementation of risk-based audit will increase the level of fraud prevention.

In addition, Arens et al. (2010) said that audit committee is members of board of directors who are responsible for helping auditors maintain their independence and provide professional opinions on company information. Gusnardi (2011), in his research, stated that the audit committee can prevent fraud. In addition, Mwangi et al. (2017) and Okpala (2012) stated that the audit committee also affects the quality of financial statements. However, there are differences with the results of research by Nugrahani (2015), which states that the audit committee has no effect on the quality of financial statements.

Another fraud prevention factor is the whistleblowing system. According to Dyck et al. (2010), organizations recognize the importance of whistleblowing in disclosing fraud after seeing a lot of evidence in the twenty-first century, such as the collapse of Enron and Arthur Andersen, a phenomenon that is revealed due to whistleblowing behavior. Whistleblowing can be explained as the act of divulging fraud committed by a person or several employees within the company to their superiors or other parties (Qusqas & Kleiner, 2001). Suastawan, Sudjana, and Sulindawati (2017), in their research, stated that whistleblowing has an effect on fraud prevention, but it is different from Cahyo and Sulhani (2017), who stated that whistleblowing has no effect on fraud prevention.

By considering several factors that affect the prevention of fraud with various results that differ from previous studies, the researcher is interested in re-examining the effect of internal control, internal audit, and audit committee on fraud prevention. Certainly, many previous researchers with different limitations and combinations of variables have conducted this study. Therefore, this study is modified by

adding other variables such as risk-based audit that are closely related to internal auditors. Considering that not all internal auditors in companies use risk-based audit, the researcher added risk-based audit as another variable that is believed to influence fraud prevention and have implications for the quality of financial statements. Apart from those variables, the researcher also includes the whistleblowing system as an independent variable, which is believed to affect fraud prevention. The difference between this study and previous studies is that the variables tested are not only for fraud prevention but also have implications for the quality of company's financial statements. In other words, fraud prevention is an intervening variable in this study. So, the novelty of this study is more complex, not only consisting of direct research of 5 independent variables on the dependent variable but also using path analysis that is indirect research by adding intervening variable and tested either partially or simultaneously.

The selected population in this study is the chemical and pharmaceutical sub-sector listed on the Indonesia Stock Exchange (IDX) because these sectors make a significant contribution to Indonesia's economic growth. Sutriyanto (2018) reported the pharmaceutical industry, chemical medicinal products, and traditional medicines grew by 6.85% and contributed 0.48% in 2017, with an investment value that increased by 35.65%. In the same year, additional investment in the pharmaceutical sector has reached IDR 5.8 trillion. Moreover, the chemical sub-sector is also selected because it is similar and related to the pharmaceutical sub-sector. Another reason for researching this sector is major frauds found in this sector, such as PT Kimia Farma. It is expected that there will be no more cases of fraud in the main sectors that have contributed to the Gross Domestic Product (GDP). The number of chemical and pharmaceutical companies listed on the Indonesia Stock Exchange is relatively small compared to other companies in other subsectors, this makes the researcher interested in analyzing fraud and collecting the data easily due to the scope of the population is on a limited scale. Therefore, the results of the analysis are concise accurate, and represent the whole population.

In this study, the independent variables (internal control, internal audit, risk-based audit, audit committee, and whistleblowing system) are the variables that affect the dependent variable (quality of financial statements) through the intervening variable (fraud prevention). The hypotheses of the study can be described as follows:

- Effect of Internal Control on Fraud Prevention

Dabbagolu (2012) said that the effectiveness of internal control, which is an indicator of success in achieving company goals, is directly related to fraud that occurs in the business world. According to Gusnardi (2011), internal control has a significant effect on fraud prevention. This statement is supported by research from Maliawan, Sujana, and Diatmika (2017). Based on the description above, the first hypothesis proposed is as follows:

H1: Internal control has a positive and significant effect on fraud prevention.

- Effect of Internal Audit on Fraud Prevention

Hassink et al. (2009) stated that competent audit performance and standards can encourage fraud prevention in a company so that the possibility of fraud can be minimized. The research from Gusnardi (2011) as well as Maliawan, Sujana, and Diatmika (2017) shows that internal audit has a significant effect on fraud prevention. Based on the description above, the second hypothesis proposed is as follows:

H2: Internal audit has a positive and significant effect on fraud prevention.

- Effect of Risk-Based Audit on Fraud Prevention

A risk-based audit is a checking method used to ensure that risks are managed within the risk limits set by the company management. This audit approach becomes the organization's control inspection system and enhances the ability to examine fraud. According to research by Rozali and Mohammad (2015), there is a positive effect between the implementation of risk-based audit and fraud prevention. Based on the description above, the third hypothesis proposed is as follows:



H3: Risk-based audit has a positive and significant effect on fraud prevention.

- Effect of Audit Committee on Fraud Prevention

Based on *Ikatan Komite Audit Indonesia* (2010), it is known that the audit committee is expected to improve the quality of internal control and optimize the checks and balances mechanism, with the aim of providing maximum protection to shareholders and stakeholders. The results of Gusnardi's research (2011) show that the role of the audit committee has a significant effect on fraud prevention. Based on the description above, the fourth hypothesis proposed is as follows:

H4: Audit committee has a positive and significant effect on fraud prevention.

- Effect of Whistleblowing System on Fraud Prevention

According to Lee & Xiao (2018), whistleblowing has a significant impact on the organization, public, and society at large. It is believed that whistleblowing is a mechanism that exposes the fraud and organizational wrongdoing. The research by Suastawan, Sujana, and Sulindawati (2013) show that whistleblowing has a significant positive effect on fraud prevention. This concurs with research by Cahyo and Sulhani (2017). Based on the description above, the fifth hypothesis proposed is as follows:

H5: Whistleblowing System has a positive and significant effect on fraud prevention.

- Effect of Internal Control, Internal Audit, Risk-based Audit, Audit Committee, and Whistleblowing System Simultaneously on Fraud Prevention

As previously explained, it is expected that internal control, internal audit, risk-based audit, audit committee, and whistleblowing system will simultaneously affect fraud prevention. Based on the description above, the sixth hypothesis proposed is as follows:

H6: Internal control, internal audit, risk-based audit, audit committee, and whistleblowing system simultaneously have a positive and significant effect on Fraud Prevention.

- Effect of Internal Control on the Quality of Financial Statements

Considering that the purpose of the internal control system is to maintain the reliability of financial statements, it is believed that the internal control system can affect the quality of financial statements by minimizing errors in the presentation of accounting data. This statement is supported by Pramudityo's research (2017) which states that the internal control system affects the quality of financial statements. Meanwhile, Widyaningtiyas (2014) states that the internal control system has a negative and insignificant effect on the quality of financial statements. Based on the description above, the seventh hypothesis proposed is as follows:

H7: Internal control has a positive and significant effect on the quality of financial statements.

- Effect of Internal Audit on the Quality of Financial Statements

Coetzee dan Lubbe (2014) stated that internal auditors not only ensure that the main risks have been addressed but also the company's business activities are carried out more effectively and efficiently so that the information presented in the financial statements is free from manipulation. According to research by Pramudityo (2017), the role of internal audit affects the quality of financial statements. However, research by Widyaningtiyas (2014) states that the capacity of internal auditors has a negative and insignificant effect on the quality of financial statements. Based on the description above, the eighth hypothesis proposed is as follows:

H8: Internal audit has a positive and significant effect on the quality of financial statements.

- Effect of Risk-Based Audit on the Quality of Financial Statements

A risk-based audit is an audit approach that starts with a risk assessment process so that the planning, implementation, and reporting of the audit is focused on important areas that are at risk of irregularities or fraud. Febriandi (2017), in his research, found that the application of risk-based audit will make auditing more effective and efficient because it prioritizes high-risk areas. Based on the description above, the ninth hypothesis proposed is as follows:

H9: Risk-based audit has a positive and significant effect on the quality of financial statements.

- Effect of Audit Committee on the Quality of Financial Statements

The Audit Committee has a duty to assist the Board of Commissioners in overseeing the preparation of financial statements in order to fulfill its integrity. Mwangi et al. (2017) said that audit committees must have audit committee diversity in order to execute their roles and mandate effectively. This will enhance the quality of their financial statements. Moreover, Okpala (2012), in his study result shows that there is a significant relationship between audit committee activities and the integrity of financial statements, which enhances the quality of corporate governance and prevents corporate failure. Meanwhile, Nugrahani (2015) states that the audit committee had no effect on the quality of financial statements. Based on the description above, the tenth hypothesis proposed is as follows:

H10: Audit committee has a positive and significant effect on the quality of financial statements.

- Effect of Whistleblowing System on the Quality of Financial Statements

In order to minimize distortion in financial statements, companies need someone who is able to present highly unethical evidence. One of the ways to prevent accounting fraud is by whistleblowing which aims to restore public trust. The importance of whistleblowing in the company will be a warning or a witness for someone who commits fraud in financial statements. Based on the description above, the eleventh hypothesis proposed is as follows:

H11: Whistleblowing system has a positive and significant effect on the quality of financial statements.

- Effect of Fraud Prevention on the Quality of Financial Statements

A financial statement is essential and free from material misstatement. Lou & Wang (2009) found a correlation between prevention of fraud and legitimacy of financial statements. With the existence of fraud prevention measures, it is believed that the quality of the

financial statements will be better and more reliable (Albrecht et al., 2012). Based on the description above, the twelfth hypothesis proposed is as follows:

H12: Fraud prevention has a positive and significant effect on the quality of financial statements.

- Effect of Internal Control, Internal Audit, Risk-based Audit, Audit Committee, and Whistleblowing System Simultaneously on the Quality of Financial Statements through Fraud Prevention.

As previously explained regarding the effect of each independent variable on the dependent variable through the intervening variables in this study, it is expected that internal control, internal audit, risk-based audit, audit committee, and whistleblowing system will simultaneously affect the quality of financial statements through fraud prevention. Based on the description above, the thirteenth hypothesis proposed is as follows:

H13: Internal control, internal audit, risk-based audit, audit committee and whistleblowing system simultaneously have a positive and significant effect on the quality of financial statements through fraud prevention.

## METHODS

This type of study is the Causal Association Research, which is to determine the effect of cause and effect between independent variables on the dependent variable either directly or through intervening variables. The type of data in this study is quantitative data. The sample consisted of 7 companies from 12 populations of chemical sub-sector companies and five companies from 10 populations of pharmaceutical sub-sector companies listed on the Indonesia Stock Exchange (IDX) in 2018. Respondents in this study were the audit committee, internal auditors, managers, supervisors, and accounting staff working in chemical and pharmaceutical companies listed on the IDX. The sources of data were primary data using questionnaires, with 180 respondents according to the number of samples that met the criteria of purposive sampling. The responder and processed were 154 (85.6%). The analysis technique using Structural Equation Modeling (SEM) and processed with Lisrel 8.8. Before

analyzing SEM, this study begins with descriptive statistical analysis and data normality test. SEM analysis consists of 2 models, measurement and structural. The measurement model is carried out by Confirmatory Factor Analysis (CFA).

The variable in this study is the latent variable, which is a factor that cannot be directly observed; therefore, it needs a manifest variable assigned to it as an indicator to test whether it exists. CFA is useful for testing a construct with unidimensionality or whether the indicators confirm a construct (dimensions or variable). According to Hair et al. (2009), the higher the loading factor value means the higher the indicators can measure the construct. In other words, the data is valid. Meanwhile, to test the reliability of each indicator-to-dimensions and dimensions-to-variables, it is calculated using the Construct Reliability and Average Variance Extracted formula. The value of Construct Reliability (CR) is derived from the square of the total value (sum) of standard loading divided by the square of the total standard loading value plus the sum error value, then the value of Average Variance Extracted (AVE) is derived from the sum (total) value squared of standard loading divided by the sum square of the standard loading plus the value of the sum error. Furthermore, Hair et al. (2009) said that the rules of thumb for construct validity are: a) standardized loading factor (SLF) of 0.5 or higher to meet construct validity; b) average variance extracted (AVE) of 0.5 or greater to suggest adequate convergent validity; and c) construct reliability (CR) of 0.7 or higher to indicate adequate convergence or internal consistency.

After testing CFA analysis, it is continued with the SEM Full Model analysis known as the Hybrid model (a combination of measurement and structural model) and a structural model that describes path analysis.

## RESULT AND DISCUSSION

Descriptive statistical analysis in this study consisted of the mean and deviation standard as presented in Table 2.

The data normality test (presented in Table 3) was only performed with the test of univariate normality for continuous variables on Lisrel 8.8. The test of multivariate normality

was not conducted because the data used were individual. From the results of the data normality test, it is known that each indicator on skewness and kurtosis on the univariate normality test has a P-value > 0.05, so that the data is normally distributed.

To test the validity and reliability of each indicator-to-dimensions and dimensions-to-variables used Confirmatory Factor Analysis. The CFA results for each variable (exogenous and endogenous) that describe each dimension and its indicators can be seen in Figure 1 to Figure 7. Each indicator at the Lisrel output has a t-count > 1.96 so that all indicators are positive and significant to form the dimensions. Furthermore, each dimension also has a t-value > 1.96, so that all dimensions are positive and significant to form the variables.

In addition, it is also known from the output of the test results (presented in Table 4 and Table 5) that all values, both indicators, and dimensions have a Standardized Loading Factor (SLF)  $\geq 0.5$ , which means that they meet the validity. However, in Table 4, there are two indicators, EWS1 and DPH2, with loading factors of 0.48 and 0.49, respectively. Hair et al. (2009) said that a sample of 150 has an SLF value  $\geq 0.45$ , so it is still considered valid. Table 4 and Table 5 also present Construct Reliability and Average Variant Extracted as reliability tests for indicators and dimensions that are calculated manually. The calculation results of these tests meet the criteria  $CR \geq 0.7$  and  $AVE \geq 0.5$ , so it is said to be reliable.

The next analysis is the SEM Full Model, which can be seen in Figure 8. It is known that all indicators of each variable, positive and significant to form the dimensions and all dimensions positive and significant to form the variables, indicated by t-count > 1.96. Furthermore, to test the validity and reliability obtained the SLF value  $\geq 0.5$ ; CR value  $\geq 0.7$  and AVE value  $\geq 0.5$  then the validity and reliability test for indicators-to-dimensions and dimensions-to-variables are valid and reliable.

Before testing the structural model, it is necessary to test the Goodness of Fit Indices Full Model that can be seen in Table 6. From the results of this test, an objective estimate is obtained that almost all model fit parameters meet the cut-off goodness of fit requirements except for  $\chi^2$ -chi square which does not meet the criteria, then Goodness of Fit Index (GFI) and

Adjusted Goodness Fit Of Index (AGFI) are categorized as marginal fit but still acceptable. Therefore, overall the SEM model has a good ability in matching the sample data.

For structural testing, it can be seen by compiling the path equations for the exogenous variables and the endogenous variables in the Standardized Solution and T-Values shown in Figure 9 and Figure 10. The complete model path analysis can be seen from the test results of this structural model.

Based on the results of the path diagram model in Figures 9 and Figure 10, a structural equation can be drawn up in the Standardized Solution for the study variables as follows:

Sub-Structural Equation I

$$PKF = 0.52*PI + 0.83*AI + 0.47*RBA + 0.59*KA - 0.11*WS, \text{Errorvar} = 0.21, R^2 = 0.79$$

Sub-Structural Equation II:

$$KLK = 0.85*PKF + 0.42*PI + 0.56*AI + 0.09*RBA - 0.18*KA + 0.68*WS, \text{Errorvar} = 0.14, R^2 = 0.86$$

KLK : Quality of Financial Statements  
PKF : Fraud Prevention  
PI : Internal Control  
AI : Internal Audit  
RBA : Risk-Based Audit  
KA : Audit Committee  
WS : Whistleblowing System  
Errorvar : Error  
R<sup>2</sup> : Coefficient of Determination

The next analysis is the t-statistic with Lisrel 8.8 (presented in table 7), the following results are obtained:

Internal Control with a positive path coefficient of 0.52 has a t-count of 5.83 > t-table 1.98, then H1 is accepted, which means the internal control (X1) partially has a positive and significant effect on Fraud Prevention (Y). The results of this study are in line with the research of Gusnardi (2011) and research by Maliawan, Sujana, and Diatmika (2017), which found a significant effect of internal control on fraud prevention. The results of this study prove that the higher the internal control, the better the fraud prevention level. Internal control within the company can prevent the possibility of fraud risk that could threaten the achievement of the business entity's goals.

Internal Audit with a positive path coefficient of 0.83 has a t-count of 7.24 > t-table

1.98, then H2 is accepted, which means the internal audit (X2) partially has a positive and significant effect on Fraud Prevention (Y). The results of this study support the previous research of Gusnardi (2011) and research of Maliawan, Sujana, and Diatmika (2017) which found that there is a significant effect of internal audit on fraud prevention. Positive and significant results indicate that the better the role of internal audit, the better the level of fraud prevention in the company. Internal audit is an important factor for companies to encourage fraud prevention to run properly and effectively so that the possibility of fraud can be minimized.

Risk-based audit with a positive path coefficient of 0.47 has a t-count of 4.60 > t-table of 1.98, then H3 is accepted, which means risk-based audit (X3) partially has a positive and significant effect on Fraud Prevention (Y). The results of this study are in line with the research of Rozali and Mohammad (2015), which states that there is a positive effect between the implementation of risk-based audit and fraud prevention. This proves that the better the implementation of risk-based audit, the better the prevention of fraud in the company because risk-based audit can be a system of checks and balances on organizational control and increases the ability to identify fraud or other problems.

The Audit Committee with a positive path coefficient of 0.59 has a t-count of 5.32 > t-table 1.98, then H4 is accepted, which means the audit committee (X4) partially has a positive and significant effect on Fraud Prevention (Y). The results of this study are in line with Gusnardi's (2011) research, which states that the role of the audit committee has a significant effect on fraud prevention. This proves the importance of the audit committee in preventing fraud. With the supervision of the audit committee in the company, the level of fraud can be minimized.

Whistleblowing System with a negative path coefficient of -0.11 has t-count -1.24 < t-table 1.98 then H5 is rejected, which means the internal control (X5) partially has a negative and insignificant effect on Fraud Prevention (Y). The results of this study contradict the research of Suastawan, Sujana, and Sulindawati (2013) and the research of Cahyo and Sulhani (2017), which found that whistleblowing has a

significant positive effect on fraud prevention. The results of this study differ from previous studies due to differences in the number of samples, objects, and time of the study. The reason for the rejection of this hypothesis is presumably due to differences in respondents' perceptions and lack of understanding of the whistleblowing system, which is a new variable that has not been widely studied in previous research.

Internal control with a positive path coefficient of 0.42 has a t-count of  $3.65 > t$ -table of 1.98 then H7 is accepted, which means the internal control (X1) partially has a positive and significant effect on the Quality of Financial Statements (Z). The results of this study are in line with the research of Pramudityo (2017) which shows that internal control has an effect to the quality of financial statements. However, it is different from Widyaningtias (2014), in her research; the internal control system has a negative and insignificant effect on the quality of financial statements. The positive and significant results in this study prove that increasing internal control will increase the quality of financial statements. This is because the internal control system can minimize errors in the presentation of accounting data, produce correct statements, and detect the possibility of fraud.

Internal Audit with a positive path coefficient of 0.56 has a t-count of  $4.05 > t$ -table of 1.98 then H8 is accepted, which means the internal audit (X2) partially has a positive and significant effect on the quality of financial statements (Z). The results of this study support Pramudityo's (2017) previous research, in which the role of internal audit has an effect on the quality of financial statements. However, it is different from the research of Widyaningtias (2014), which states that the capacity of internal auditors has a negative and insignificant effect on the quality of financial statements. The positive and significant results in this study indicate that the better the role of internal audit, the better the quality of the financial statements. Internal audit with a systematic examination of the records, procedures, and operations of the company can prevent misstatements in financial statements.

Risk-Based Audit with a positive path coefficient of 0.09 has a t-count of  $0.70 < t$ -table 1.98, then H9 is rejected, which means the risk-

based audit (X3) partially has a positive and insignificant effect on the quality of financial statements (Z). The results of this study contradict the research of Febriandi (2017), which found that risk-based audit will make financial statements auditing more effective and efficient. The reason for the rejection of the hypothesis can be assumed because not many companies have implemented risk-based audits in their companies or business entities. In addition, it does not rule out that respondents do not understand the definition of risk-based audit and how it applies within the company. Risk-based audit is also a new variable added in this study, and not many researchers have examined this variable.

The Audit Committee with a negative path coefficient of -0.18 has a t-count of  $-1.00 < t$ -table 1.98, then H10 is rejected, which means the audit committee (X4) partially has a negative and insignificant effect on the quality of financial statements (Z). The results of this study are in line with Nugrahani's (2015) research, which states that the audit committee has no effect on the quality of financial statements. However, this study is different from Mwangi et al. (2017), which shows that the diversity of the audit committee affects the quality of financial statements and Okpala (2012), which found that there is a significant relationship between audit committee activities and integrity of financial statements. The results of the study were different from previous studies due to differences in the number of samples, objects, and time of the study. The reason for the rejection of this hypothesis is allegedly because the respondent did not understand the items of the question and the researcher could not confirm whether the questionnaire was filled in by the relevant party.

Whistleblowing System with a positive path coefficient of 0.68 has a t-count of  $6.70 > t$ -table 1.98, then H11 is accepted, which means the whistleblowing system (X5) partially has a positive and significant effect on the quality of financial statements (Z). Positive and significant results prove that the better the application of the whistleblowing system, the better the quality of financial statements. The importance of whistleblowing in a company is a key element of anti-corruption and fraudulent financial statements in order to prevent losses for the company.

Fraud prevention with a positive path coefficient of 0.85 has a t-count of  $10.32 > t$ -table 1.98, then H12 is accepted, which means the fraud prevention (Y) partially has a positive and significant effect on the Quality of Financial Statements (Z). Positive and significant results indicate that the existence of fraud prevention measures can increase the legitimacy of corporate financial statements, consistent with research by Lou & Wang (2009). Establishment of fraud prevention policies and procedures can help management provide adequate assurance in financial statements.

Next, for the F test (presented in Table 8), H6 has an F-count value of  $111.352 > F$ -table of 2.28 then H6 is accepted, which means internal control, internal audit, risk-based audit, audit committee, and whistleblowing system simultaneously have a positive and significant effect on fraud prevention. Then for H13 has an F-count value of  $181.829 > F$ -table of 2.28, then H13 is accepted, which means internal control, internal audit, risk-based audit, audit committee, and whistleblowing system simultaneously have a positive and significant effect on the quality of financial statements through fraud prevention.

From Table 8, the effect of internal control (X1), internal audit (X2), risk-based audit (X3), audit committee (X4), and whistleblowing system (X5) simultaneously on fraud prevention (Y) have a coefficient of determination of 0.79. This means that the ability of these independent variables to explain fraud prevention is 79%, while the remaining 21% can be explained by other variables out of this study. Furthermore, the effect of internal control (X1), internal audit (X2), risk-based audit (X3), audit committee (X4), and whistleblowing system (X5) simultaneously on the quality of financial statements (Z) through fraud prevention (Y) have a coefficient of determination of 0.86. This means that the ability of these independent variables in explaining the quality of financial statements through fraud prevention is 86% while the remaining 14% can be explained by other variables out of this study.

## CONCLUSION

Partially, internal control and internal audit have a positive and significant effect on fraud prevention. The results of this study are supported by Gusnardi (2011) and Maliawan, Sujana, and Diatmika (2017). The effectiveness of internal control and internal audit not only plays an important role in the successful achievement of organizational goals but is also directly related to fraud detection within the company. In addition, risk-based audit and audit committees partially affect fraud prevention positively and significantly. This is in line with the study of Rozali and Mohammad (2015). Risk-based audit approach focuses more on reviewing strategic, operational, financial, regulatory, and other risks faced by the organization. Likewise, the audit committee embodies corporate discipline to reduce the chance of irregularities, identifying various types that require attention in the organization. Meanwhile, the whistleblowing system partially has a negative and insignificant effect on fraud prevention. The results of this study contradict the research of Suastawan, Sujana, and Sulindawati (2013) and the research of Cahyo and Sulhani (2017), which found that whistleblowing has a significant positive effect on fraud prevention due to differences in respondents' perceptions and lack of understanding of the whistleblowing system. However, simultaneously, the direct effect of internal control, internal audit, risk-based audit, audit committee, and whistleblowing system on fraud prevention has a positive and significant effect.

The results of the further study indicate that partially internal control and internal audit have a positive and significant effect on the quality of financial statements. The results of this study support Pramudityo's (2017) previous research but it is different from Widyaningtiyas (2014), which stated that the internal control and internal audit has a negative and insignificant effect on the quality of financial statements. Internal control ensures the company's management runs well and shows the accuracy of financial statements while internal audit examines financial statements as well as compliance with top management and regulatory policies. The next result shows that risk-based audit partially has a positive but

insignificant effect on the quality of financial statements. This can occur because not many companies have implemented a risk-based audit approach in their business entities. In addition, audit committee partially has a negative and insignificant effect on the quality of financial statements. The results of this study are in line with Nugrahani's (2015) research, which stated that the audit committee has no effect on the quality of financial statements, but it is different from Mwangi et al. (2017) and Okpala (2012), which stated that audit committee affects the quality of financial statements. Moreover, the whistleblowing system and fraud prevention partially have a positive and significant effect on the quality of financial statements. In the whistleblowing system, there are mechanisms for the delivery of important information, early detection, and focus on corrective actions to produce reliable financial statements. Fraud prevention has also been proven to improve the quality of financial statements, consistent with research by Lou & Wang (2009). However, simultaneously, the indirect effect of internal control, internal audit, risk-based audit, audit committee, whistleblowing system on the quality of financial statements through fraud prevention (as an intervening variable) have a positive and significant effect.

The results of this study are expected to contribute and have implications for interested parties. For scientific development, it is hoped that it can increase knowledge about the factors that affect fraud and the quality of financial statements. In addition, it also assists the development process on these factors, as well as make it easier to identify 'red flags' to detect fraud in companies so that the resulting financial reports are more reliable. For company management, it is hoped that the company will further improve its internal supervision and control system in order to avoid and reduce fraud committed by certain parties, both from inside and outside the company. In the future, the company will pay more attention to the quality of internal control, internal auditors, risk-based audit approaches, audit committees, and whistleblowing systems to enhance fraud prevention so that the company's goals can be achieved.

## REFERENCES

- Albrecht, W. S., Albrecht, C. O., Albrecht C. C., & Zimbelman, M. F. (2012). *Fraud Examination, 4th Ed.* Mason, Ohio: South Western Cengage Learning.
- Arens, A. A., Elder, R. J., Beasley, M. S. (2010). *Auditing and Assurance Services: An Integrated Approach, 13th Edition.* New Jersey: Pearson Prentice Hall.
- Cahyo, M. N., & Sulhani. (2017). Analisis Empiris Pengaruh Karakteristik Komite Audit, Karakteristik internal Audit, Whistleblowing System, Pengungkapan Kecurangan Terhadap Reaksi Pasar. *Jurnal Dinamika Akuntansi dan Bisnis*, 4(2), 249-270. doi: 10.24815/JDAB.V4I2.7704
- Caturini, R & Hidayat, A. (2018, 07 Feb). Kontan: *Tumbuh 5,14% di 2017 Industri Masih Jadi Kontributor Terbesar PDB Nasional.* Retrieved July 05<sup>th</sup> 2018 from <https://industri.kontan.co.id/news/tumbuh-514-di-2017-industri-masih-jadi-kontributor-terbesar-pdb-nasional>
- Coetzee, H & Lubbe, D. (2014). Improving The Efficiency and Effectiveness of Risk-Based Internal Audit Engagements. *International Journal of Auditing*, 18(2), 115-125.
- Committee of Sponsoring Organizations of the Treadway Commission (COSO). (2013). *Internal Control – Integrated Framework: Executive Summary.* Durham, N.C.: American Institute of Certified Public Accountants.
- Dabbagoglu, K. (2012). Fraud in Business and Internal Control System. *Journal of Modern Accounting and Auditing*, 8(7), 983-989.
- Dyck, A., Morse, A., Zingales, L. (2010). Who blows the whistle on corporate fraud? *The Journal of Finance*, 65(6), 2213-2253. doi: 10.1111/j.1540-6261.2010.01614.x

- Febriandi, F. (2017). *Analisis Kualitatif Penerapan Audit Berbasis Risiko Dalam Pembuatan Perencanaan Audit Pada Perwakilan BPKP Provinsi Lampung*. Thesis. Universitas Lampung.
- Fitzsimmons, J. A., & Fitzsimmons, M. J. (2017). *Service Management: Operations, Startegy, Infromation Technology 7th Ed*. New York: McGraw Hill Education.
- Gusnardi. (2011). Pengaruh Peran Komite Audit, Pengendalian Internal, Audit Internal dan Pelaksanaan Tata Kelola Perusahaan Terhadap Pencegahan Kecurangan. *Jurnal Ekonomi dan Keuangan, EKUITAS*, 15(1), 130-146. doi:10.24034/j25485024.y2011.v15.i1.196
- Hair Jr., J. F., Black, W. C., Babin, B. J., Anderson, R. E. (2009). *Multivariate Data Analysis (7th Edition)*. New Jersey: Pearson Prentice Hall.
- Hassink, H. F. D., Bollen, L. H., Meuwissen, R. H. G., & Vries, M. J. (2009). Corporate Fraud and The Audit Expectations Gap: A Study Among Business Managers. *Journal of International Accounting, Auditing and Taxation, Elsevier*, 18(2), 85-100. doi: 10.1016/j.intaccaudtax.2009.05.003
- Ikatan Komite Audit Indonesia (IKAI), *Tentang Komite Audit*. Retrieved Juli 20<sup>th</sup> 2018 from <https://www.ikai.id/tentang-komite-audit/>
- Lee, G., & Xiao, X. (2018). Whistleblowing on Accounting-Related Misconduct: A Synthesis of the Literature. *Journal of Accounting Literature, Elsevier*, 41, 22-46. doi: 10.1016/j.acclit.2018.03.003
- Lou, Y.-I., & Wang, M.-L. (2009). Fraud Risk Factor Of The Fraud Triangle Assessing The Likelihood Of Fraudulent Financial Reporting. *Journal of Business & Economics Research (JBBER)*, 7(2). doi: 10.19030/jber.v7i2.2262
- Kusnadi, Y., Leong, K. S., Suwardy, T., & Wang, J. (2015). *Audit Committees and Financial Reporting Quality in Singapore*. Available at SSRN 2467456
- Maliawan, I. B. D., Sujana, E., Diatmika, I. P. G. (2017). Pengaruh Audit Internal dan Efektivitas Pengendalian Interen Terhadap Pencegahan Kecurangan (Fraud). *E-Journal SI Ak Universitas Pendidikan Ganesha*, 8(2). doi: 10.23887/jimat.v8i2.13355
- Mwangi, K. A., Oluoch, J. O., Muturi, W., & Florence, M. (2017). Effect of Audit Committee Diversity on Quality of Financial Reporting in Non-Commercial State Corporations in Kenya. *International Journal of Academic Research in Business and Social Sciences*, 7(6), 288-302.
- Nayoan. S., & Masruchin. (2017). Pengaruh Kesiapan Auditor dan Manajemen Risiko Terhadap Tata Kelola Perusahaan Dengan Variabel Mediator Risk Based Audit. *Jurnal Bisnis dan Komunikasi, KALBIS SOCIO*, 4(2), 144-148.
- Nugrahani, T. S. (2015). Pengaruh Dewan Komisaris dan Komite Audit Pada Kualitas Laporan Keuangan. *Jurnal Akuntansi dan Manajemen AKMENIKA*, 14(1).
- Okpala, K. E. (2012). Audit Committee and Integrity of Financial Statements: A Preventive Mechanism for Corporate Failure. *Australian Journal of Business and Management Research*, 2(8), 32-40.
- Petrascu, D., & Tieanu, A. (2014). The Role of Internal Audit in Fraud Prevention and Detection. *Procedia Economics and Finance, Elsevier*, 16, 489-497. doi: 10.1016/S2212-5671(14)00829-6
- Pramudityo, B. (2017). *Pengaruh Kompetensi Sumber Daya Manusia, Pemanfaatan Sistem Informasi*



- Akuntansi Keuangan Daerah, Sistem Pengendalian Intern dan Peran Internal Audit Terhadap Kualitas Laporan Keuangan Pemerintah Daerah* (Thesis). Available from Electronic Theses and Dissertations Universitas Muhammadiyah Surakarta. (UMS No. 51796)
- Pusdiklatwas BPKP. (2008). *Fraud Auditing (5th Ed)*. Jakarta: BPKP
- Qusqas, F & Kleiner, B. H. (2001). The Difficulties of Whistleblowers Finding Employment. *Management Research News*, 24(3/4), 97-100. doi: 10.1108/01409170110782702
- Rabiu, A. M & Mansor, N. (2015). Forensic Accounting and Frauds Risk Factors: The Influence of Fraud Diamond Theory. *The American Journal of Innovative Research and Applied Sciences*, 1(5), 186-192.
- Rezaee, Z. (2005). Causes, Consequences, and Deterrence of Financial Statement Fraud. *Critical Perspective on Accounting, Elsevier*, 16(3), 277-278. doi: 10.1016/S1045-2354(03)00072-8
- Rozali, R. D. Y., & Mohammad, R. (2015). Pengaruh Pelaksanaan Risk Based Internal Auditing Terhadap Pencegahan Fraud. *Jurnal Riset Akuntansi dan Keuangan*, 3(3), 831-836. doi: 10.17509/jrak.v3i3.6623
- Sariah, J. (2010). *Analisis Pengaruh Peran Komite Audit dan Pengendalian Intern Terhadap Kinerja Keuangan* (Thesis). Available from Institutional Repository UIN Syarif Hidayatullah Jakarta. (UINJKT No. 3587)
- Semendawai, A. H. et al. (2011). *Memahami Whistleblower*. Jakarta: Lembaga Perlindungan Saksi dan Korban.
- Setyaningsih, R. D. (2016). Pengaruh Kinerja Lingkungan Terhadap Kinerja Keuangan Dengan Corporate Social Responsibility Sebagai Pemoderasi. *Jurnal Ilmu dan Riset Akuntansi (JIRA)*, 5(4), 1-15.
- Suastawan, I. M. I. D. P., Sujana, E., Sulindawati, N. L. G. E. (2017). Pengaruh Budaya Organisasi, Proactive Fraud Audit, dan Whistleblowing Terhadap Pencegahan Kecurangan Dalam Pengelolaan Dana BOS. *E-Journal SI Ak Universitas Pendidikan Ganesha*, 7(1). doi: 10.23887/jimat.v7i1.10240
- Sutriyanto, E. (2018, 20 Mar). *Industri Farmasi Berkontribusi Signifikan Bagi Perkembangan Ekonomi Indonesia*. Retrieved July 27<sup>th</sup> 2018 from <https://www.tribunnews.com/bisnis/2018/03/20/industri-farmasi-berkontribusi-signifikan-bagi-perkembangan-ekonomi-indonesia>.
- Widyaningtias, E. (2014). *Pengaruh Sistem Pengendalian Internal, Pemanfaatan Teknologi Informasi dan Kapasitas Auditor Internal Terhadap Kualitas Laporan Keuangan Bank Pembiayaan Rakyat Syariah se-Jabodetabek* (Thesis). Available from Institutional Repository UIN Syarif Hidayatullah Jakarta. (UINJKT No. 25102)

Table 1 Dimensions and Indicators of Independent and Dependent Variables

| Variable   | Dimension                                      | Indicator   | Measurement       |
|--|--|---|-------------------|
| Internal Control (X <sub>1</sub> )<br>(COSO, 2013)               | 1. Control environment                         | - Value of integrity and ethics<br>- Philosophy and management style  | Likert Scale 1-5  |
|  | 2. Risk assessment                             | - Identification of risk<br>- Risk analysis   | SD, MD, N, MA, SA |
|  | 3. Control activities                          | - Design and Checking<br>- Authorization and separation of functions  |                   |
|  | 4. Information and Communication               | - Reliable and relevant information<br>- Provision of information systems   |                   |
|  | 5. Monitoring                                  | - Continuous monitoring<br>- Conduct a separate evaluation  |                   |
| Internal Audit (X <sub>2</sub> )<br>(Fitzsimmons & Mona, 2011)   | 1. Independence                                | - Free, honest and objective<br>- Assignment of audit responsibility  | Likert Scale 1-5  |
|  | 2. Professional expertise                      | - Education and expertise<br>- Proficiency and finesse  | SD, MD, N, MA, SA |
|  | 3. Scope of inspection work                    | - Evaluation of the effectiveness of internal control<br>- Implementation of responsibility                             |                   |
|  | 4. Implementation of work                      | - Planning, review and evaluation<br>- Communicating results and follow-up  |                   |
| Risk-based Audit (X <sub>3</sub> )<br>(Nayoan & Masruchin, 2017) | 1. Planning                                    | - Determination of targets and proper focus<br>- Consideration of duration and resources                                | Likert Scale 1-5  |
|  | 2. Execution Audit Plan                        | - Audit scope in accordance with the focus of improvement<br>- Audit scope when conducting the audit                    | SD, MD, N, MA, SA |
|  | 3. Reporting                                   | - Recommendation and implementation<br>- Communication of examination results   |                   |
|  | 4. Review & Monitoring                         | - Implementation and follow-up<br>- Routine monitoring  |                   |
| Audit Committee (X <sub>4</sub> )<br>(Sariah, 2010)              | 1. Purpose and benefits of the audit committee | - Supervision of financial statements<br>- Monitoring risk and corporate governance                                     | Likert Scale 1-5  |
|  | 2. Responsibilities of the audit committee     | - Giving professional opinion<br>- Responsibility for the company's internal and external activities                    | SD, MD, N, MA, SA |
|  | 3. Scope of work of the audit committee        | - Audit committee charter, structure and membership requirements<br>- Audit committee meetings, performance and reports |                   |
| Whistleblowing System (X <sub>5</sub> )                          | 1. Effectiveness of the application of the     | - Condition when knowing the occurrence of fraud  | Likert Scale 1-5  |

|  |  |  |                   |
|--|--|--|-------------------|
| (Semendawai et al., 2011)                                | whistleblowing system                    | - Availability of access to reporting fraud outside the company  | SD, MD, N, MA, SA |
|  | 2. How to report fraud                   | - Internal fraud reporting<br>- External fraud reporting   |                   |
|  | 3. Benefits of the whistleblowing system | - Availability of ways of conveying information<br>- Risk reduction, reputation improvement                          |                   |
| Fraud Prevention (Y) (Pusdiklatwas BPKP, 2008)           | 1. Determination of anti-fraud policies  | - Establish an anti-fraud policy<br>- Commitment to implementing anti-fraud activities                               | Likert Scale 1-5  |
|  | 2. Standard preventive procedures        | - Separation of functions<br>- Adequate review and operation system  | SD, MD, N, MA, SA |
|  | 3. Control techniques                    | - Division of duties and supervision<br>- Manual control in processing   |                   |
|  | 4. Sensitivity to fraud                  | - Implementing a brainstorming procedure<br>- Reporting of suspicious activity                                       |                   |
| Quality of Financial Statements (Z) (Setyaningsih, 2016) | 1. Relevant                              | - Feedback and predictive benefits<br>- On time  | Likert Scale 1-5  |
|  | 2. Reliable                              | - Honest and complete presentation<br>- Can be verified  | SD, MD, N, MA, SA |
|  | 3. Comparable                            | - Can be compared with the previous year<br>- Can be compared with other entities                                    |                   |
|  | 4. Understandable                        | - Financial statement information that is easy to understand<br>- Sufficient knowledge to study financial statements |                   |

Table 2 Descriptive Statistics

| Variable                        | Item           | Mean | Deviation Standard | Variable         | Item                  | Mean | Deviation Standard |      |
|---------------------------------|----------------|------|--------------------|------------------|-----------------------|------|--------------------|------|
| Internal Control                | PI1            | 3,94 | 0,65               | Audit Committee  | KA1                   | 4,36 | 0,50               |      |
|                                 | PI2            | 4,21 | 0,63               |                  | KA2                   | 4,39 | 0,50               |      |
|                                 | PI3            | 3,73 | 0,74               |                  | KA3                   | 4,29 | 0,54               |      |
|                                 | PI4            | 4,20 | 0,71               |                  | KA4                   | 4,50 | 0,53               |      |
|                                 | PI5            | 3,84 | 0,59               |                  | KA5                   | 4,52 | 0,50               |      |
|                                 | PI6            | 3,94 | 0,59               |                  | KA6                   | 4,53 | 0,50               |      |
|                                 | Internal Audit | PI7  | 4,25               | 0,69             | Whistleblowing system | WS1  | 4,44               | 0,59 |
|                                 |                | PI8  | 3,61               | 0,80             |                       | WS2  | 4,26               | 0,64 |
|                                 |                | PI9  | 4,18               | 0,73             |                       | WS3  | 4,22               | 0,53 |
|                                 |                | PI10 | 4,08               | 0,56             |                       | WS4  | 4,35               | 0,56 |
| Risk-Based Audit                | AI1            | 4,16 | 0,66               | WS5              |                       | 4,34 | 0,63               |      |
|                                 | AI2            | 4,16 | 0,62               | WS6              |                       | 4,34 | 0,65               |      |
|                                 | AI3            | 4,20 | 0,64               | Fraud Prevention |                       | PKF1 | 4,23               | 0,68 |
|                                 | AI4            | 4,16 | 0,57               |                  |                       | PKF2 | 4,10               | 0,89 |
|                                 | AI5            | 4,23 | 0,64               |                  | PKF3                  | 4,25 | 0,64               |      |
|                                 | AI6            | 4,31 | 0,61               |                  | PKF4                  | 4,24 | 0,70               |      |
|                                 | AI7            | 4,33 | 0,61               |                  | PKF5                  | 4,28 | 0,58               |      |
|                                 | AI8            | 4,14 | 0,67               |                  | PKF6                  | 4,24 | 0,68               |      |
| Quality of Financial Statements | RBA1           | 4,29 | 0,65               |                  | PKF7                  | 4,31 | 0,62               |      |
|                                 | RBA2           | 4,34 | 0,57               |                  | PKF8                  | 4,31 | 0,67               |      |
|                                 | RBA3           | 4,38 | 0,55               | KLK1             | 4,25                  | 0,66 |                    |      |
|                                 | RBA4           | 4,26 | 0,53               | KLK2             | 4,25                  | 0,60 |                    |      |
|                                 | RBA5           | 4,12 | 0,58               | KLK3             | 4,32                  | 0,60 |                    |      |
|                                 | RBA6           | 4,14 | 0,62               | KLK4             | 4,19                  | 0,64 |                    |      |
|                                 | RBA7           | 4,25 | 0,59               | KLK5             | 4,30                  | 0,57 |                    |      |
|                                 | RBA8           | 4,33 | 0,57               | KLK6             | 4,18                  | 0,67 |                    |      |
|                                 |                |      |                    | KLK7             | 4,23                  | 0,66 |                    |      |
|                                 |                |      |                    | KLK8             | 4,19                  | 0,65 |                    |      |

Source: Processed primary data, 2020

Table 3 Test of Univariate Normality for Continuous Variables

| Variable | Skewness |         | Kurtosis |         | Skewness and Kurtosis |         |
|----------|----------|---------|----------|---------|-----------------------|---------|
|          | Z-Score  | P-Value | Z-Score  | P-Value | Chi-Square            | P-Value |
| PI1      | -0.400   | 0.689   | -0.578   | 0.563   | 0.495                 | 0.781   |
| PI2      | -1.033   | 0.302   | -2.059   | 0.070   | 5.305                 | 0.070   |
| PI3      | -0.589   | 0.556   | -0.728   | 0.467   | 0.876                 | 0.645   |
| PI4      | -1.518   | 0.129   | -4.582   | 0.064   | 23.302                | 0.060   |
| PI5      | 0.246    | 0.806   | -0.597   | 0.551   | 0.416                 | 0.812   |
| PI6      | 0.040    | 0.968   | 0.009    | 0.993   | 0.002                 | 0.999   |
| PI7      | -1.866   | 0.062   | -3.763   | 0.086   | 17.637                | 0.120   |
| PI8      | -1.680   | 0.093   | -0.764   | 0.445   | 3.404                 | 0.182   |
| PI9      | -1.479   | 0.139   | -6.163   | 0.059   | 0.168                 | 0.090   |
| PI10     | 0.154    | 0.878   | 0.605    | 0.545   | 0.390                 | 0.823   |
| AI1      | -1.617   | 0.106   | -0.220   | 0.826   | 2.663                 | 0.264   |
| AI2      | -2.280   | 0.053   | 2.037    | 0.092   | 9.348                 | 0.079   |
| AI3      | -1.760   | 0.078   | 0.359    | 0.720   | 3.228                 | 0.199   |
| AI4      | -1.109   | 0.267   | 1.879    | 0.060   | 4.761                 | 0.093   |
| AI5      | -2.007   | 0.065   | 0.266    | 0.790   | 4.099                 | 0.129   |
| AI6      | -2.257   | 0.074   | 0.964    | 0.335   | 6.021                 | 0.249   |
| AI7      | -1.485   | 0.137   | -2.217   | 0.067   | 7.120                 | 0.068   |
| AI8      | -2.168   | 0.080   | 0.864    | 0.388   | 5.446                 | 0.066   |
| RBA1     | -3.191   | 0.091   | 1.751    | 0.080   | 13.247                | 0.081   |
| RBA2     | -0.915   | 0.360   | -2.411   | 0.074   | 6.650                 | 0.256   |
| RBA3     | -0.497   | 0.620   | -3.872   | 0.089   | 15.242                | 0.340   |
| RBA4     | 0.753    | 0.451   | -1.009   | 0.313   | 1.586                 | 0.453   |
| RBA5     | -1.120   | 0.263   | 1.720    | 0.085   | 4.212                 | 0.122   |
| RBA6     | -0.469   | 0.639   | -1.201   | 0.230   | 1.662                 | 0.436   |
| RBA7     | -0.652   | 0.514   | -1.459   | 0.145   | 2.554                 | 0.279   |
| RBA8     | -0.697   | 0.486   | -2.262   | 0.094   | 5.604                 | 0.061   |
| KA1      | 2.072    | 0.048   | -17.745  | 0.061   | 19.194                | 0.520   |
| KA2      | 1.543    | 0.123   | -72.392  | 0.085   | 43.000                | 0.075   |
| KA3      | 0.612    | 0.540   | -1.840   | 0.066   | 3.760                 | 0.153   |
| KA4      | -1.400   | 0.162   | -11.612  | 0.069   | 36.797                | 0.142   |
| KA5      | -0.412   | 0.680   | 30.712   | 0.057   | 43.425                | 0.087   |
| KA6      | -0.549   | 0.583   | 30.774   | 0.070   | 47.364                | 0.093   |
| WS1      | -2.525   | 0.042   | -2.262   | 0.054   | 11.492                | 0.103   |
| WS2      | -1.430   | 0.153   | -2.322   | 0.060   | 7.438                 | 0.054   |
| WS3      | 0.987    | 0.324   | -0.140   | 0.889   | 0.994                 | 0.608   |
| WS4      | -0.436   | 0.663   | -3.015   | 0.053   | 9.281                 | 0.090   |
| WS5      | -2.049   | 0.058   | -2.372   | 0.078   | 9.824                 | 0.607   |
| WS6      | -2.336   | 0.099   | -2.549   | 0.091   | 11.958                | 0.349   |
| PKF1     | -3.844   | 0.063   | 2.519    | 0.052   | 21.123                | 0.070   |
| PKF2     | -4.100   | 0.087   | 0.669    | 0.504   | 17.257                | 0.290   |
| PKF3     | -2.201   | 0.088   | 0.283    | 0.777   | 4.924                 | 0.085   |
| PKF4     | -4.739   | 0.094   | 3.324    | 0.271   | 33.512                | 0.076   |

|      |        |       |        |       |        |       |
|------|--------|-------|--------|-------|--------|-------|
| PKF5 | -1.602 | 0.109 | 1.505  | 0.132 | 4.830  | 0.089 |
| PKF6 | -3.439 | 0.071 | 1.935  | 0.053 | 15.570 | 0.291 |
| PKF7 | -1.588 | 0.112 | -2.243 | 0.055 | 7.552  | 0.063 |
| PKF8 | -3.924 | 0.090 | 2.317  | 0.181 | 20.768 | 0.476 |
| KLK1 | -1.692 | 0.091 | -2.967 | 0.063 | 11.665 | 0.083 |
| KLK2 | -1.781 | 0.075 | 1.143  | 0.253 | 4.478  | 0.107 |
| KLK3 | -1.388 | 0.165 | -2.171 | 0.070 | 6.636  | 0.086 |
| KLK4 | -3.722 | 0.060 | 3.125  | 0.262 | 23.620 | 0.095 |
| KLK5 | -0.577 | 0.564 | -1.870 | 0.061 | 3.831  | 0.147 |
| KLK6 | -3.010 | 0.073 | 1.911  | 0.156 | 12.714 | 0.102 |
| KLK7 | -2.137 | 0.056 | -0.219 | 0.827 | 4.616  | 0.099 |
| KLK8 | -1.815 | 0.070 | -0.084 | 0.933 | 3.302  | 0.192 |

Source: The results of data processing with Lisrel 8.8

Table 4 Validity and Reliability of Indicators

| No. | Variable         | Indicator  | Loading Factor ( $\lambda$ ) | Loading Factor <sup>2</sup> ( $\lambda^2$ ) | Error ( $1 - \lambda^2$ ) | CR           | AVE          |
|-----|------------------|------------|------------------------------|---|---------------------------|--------------|--------------|
| 1   | Internal Control | LP1        | 0.84                         | 0.706                                       | 0.294                     | <b>0.906</b> | <b>0.501</b> |
|     |                  | LP2        | 0.62                         | 0.384                                       | 0.616                     |              |              |
|     |                  | PR1        | 0.85                         | 0.723                                       | 0.278                     |              |              |
|     |                  | PR2        | 0.57                         | 0.325                                       | 0.675                     |              |              |
|     |                  | AP1        | 0.54                         | 0.292                                       | 0.708                     |              |              |
|     |                  | AP2        | 0.78                         | 0.608                                       | 0.392                     |              |              |
|     |                  | IK1        | 0.56                         | 0.314                                       | 0.686                     |              |              |
|     |                  | IK2        | 0.53                         | 0.281                                       | 0.719                     |              |              |
|     |                  | PM1        | 0.88                         | 0.774                                       | 0.226                     |              |              |
|     |                  | PM2        | 0.78                         | 0.608                                       | 0.392                     |              |              |
|     |                  | $\Sigma$   | <b>6.95</b>                  | <b>5.015</b>                                | <b>4.985</b>              |              |              |
|     |                  | $\Sigma^2$ | <b>48.30</b>                 |   |                           |              |              |
| 2   | Internal Audit   | IDP1       | 0.53                         | 0.281                                       | 0.719                     | <b>0.900</b> | <b>0.539</b> |
|     |                  | IDP2       | 0.89                         | 0.792                                       | 0.208                     |              |              |
|     |                  | KP1        | 0.84                         | 0.706                                       | 0.294                     |              |              |
|     |                  | KP2        | 0.71                         | 0.504                                       | 0.496                     |              |              |
|     |                  | LKP1       | 0.59                         | 0.348                                       | 0.652                     |              |              |
|     |                  | LKP2       | 0.68                         | 0.462                                       | 0.538                     |              |              |
|     |                  | PP1        | 0.94                         | 0.884                                       | 0.116                     |              |              |
|     |                  | PP2        | 0.58                         | 0.336                                       | 0.664                     |              |              |
|     |                  | $\Sigma$   | <b>5.76</b>                  | <b>4.313</b>                                | <b>3.687</b>              |              |              |
|     |                  | $\Sigma^2$ | <b>33.18</b>                 |   |                           |              |              |
| 3   | Audit Committee  | PLN1       | 0.62                         | 0.384                                       | 0.616                     | <b>0.892</b> | <b>0.514</b> |
|     |                  | PLN2       | 0.78                         | 0.608                                       | 0.392                     |              |              |
|     |                  | EAP1       | 0.59                         | 0.348                                       | 0.652                     |              |              |
|     |                  | EAP2       | 0.81                         | 0.656                                       | 0.344                     |              |              |
|     |                  | RPT1       | 0.69                         | 0.476                                       | 0.524                     |              |              |
|     |                  | RPT2       | 0.58                         | 0.336                                       | 0.664                     |              |              |

|   |                                 |            |              |              |              |              |              |
|---|---------------------------------|------------|--------------|--------------|--------------|--------------|--------------|
|   |                                 | RM1        | 0.84         | 0.706        | 0.294        |              |              |
|   |                                 | RM2        | 0.77         | 0.593        | 0.407        |              |              |
|   |                                 | $\Sigma$   | <b>5.68</b>  | <b>4.108</b> | <b>3.892</b> |              |              |
|   |                                 | $\Sigma^2$ | <b>32.26</b> |              |              |              |              |
| 4 | Risk-based Audit                | TM1        | 0.93         | 0.865        | 0.135        | <b>0.930</b> | <b>0.696</b> |
|   |                                 | TM2        | 0.97         | 0.941        | 0.059        |              |              |
|   |                                 | TGJ1       | 0.56         | 0.314        | 0.686        |              |              |
|   |                                 | TGJ2       | 0.73         | 0.533        | 0.467        |              |              |
|   |                                 | LK1        | 0.93         | 0.865        | 0.135        |              |              |
|   |                                 | LK2        | 0.81         | 0.656        | 0.344        |              |              |
|   |                                 | $\Sigma$   | <b>4.93</b>  | <b>4.173</b> | <b>1.827</b> |              |              |
|   |                                 | $\Sigma^2$ | <b>24.30</b> |              |              |              |              |
| 5 | Whistleblowing System           | EWS1       | 0.48         | 0.230        | 0.770        | <b>0.862</b> | <b>0.517</b> |
|   |                                 | EWS2       | 0.69         | 0.476        | 0.524        |              |              |
|   |                                 | CPP1       | 0.70         | 0.490        | 0.510        |              |              |
|   |                                 | CPP2       | 0.87         | 0.757        | 0.243        |              |              |
|   |                                 | MWS1       | 0.68         | 0.462        | 0.538        |              |              |
|   |                                 | MWS2       | 0.83         | 0.689        | 0.311        |              |              |
|   |                                 | $\Sigma$   | <b>4.25</b>  | <b>3.105</b> | <b>2.895</b> |              |              |
|   |                                 | $\Sigma^2$ | <b>18.06</b> |              |              |              |              |
| 6 | Fraud Prevention                | KAF1       | 0.67         | 0.449        | 0.551        | <b>0.889</b> | <b>0.506</b> |
|   |                                 | KAF2       | 0.64         | 0.410        | 0.590        |              |              |
|   |                                 | PPB1       | 0.84         | 0.706        | 0.294        |              |              |
|   |                                 | PPB2       | 0.65         | 0.423        | 0.578        |              |              |
|   |                                 | TP1        | 0.88         | 0.774        | 0.226        |              |              |
|   |                                 | TP2        | 0.66         | 0.436        | 0.564        |              |              |
|   |                                 | KTK1       | 0.60         | 0.360        | 0.640        |              |              |
|   |                                 | KTK2       | 0.70         | 0.490        | 0.510        |              |              |
|   |                                 | $\Sigma$   | <b>5.64</b>  | <b>4.047</b> | <b>3.953</b> |              |              |
|   |                                 | $\Sigma^2$ | <b>31.81</b> |              |              |              |              |
| 7 | Quality of Financial Statements | RLV1       | 0.57         | 0.325        | 0.675        | <b>0.898</b> | <b>0.533</b> |
|   |                                 | RLV2       | 0.88         | 0.774        | 0.226        |              |              |
|   |                                 | ADL1       | 0.69         | 0.476        | 0.524        |              |              |
|   |                                 | ADL2       | 0.74         | 0.548        | 0.452        |              |              |
|   |                                 | DBD1       | 0.58         | 0.336        | 0.664        |              |              |
|   |                                 | DBD2       | 0.86         | 0.740        | 0.260        |              |              |
|   |                                 | DPH1       | 0.91         | 0.828        | 0.172        |              |              |
|   |                                 | DPH2       | 0.49         | 0.240        | 0.760        |              |              |
|   |                                 | $\Sigma$   | <b>5.72</b>  | <b>4.267</b> | <b>3.733</b> |              |              |
|   |                                 | $\Sigma^2$ | <b>32.72</b> |              |              |              |              |

Source: Processed primary data, 2020

Table 5 Validity and Reliability of Dimensions

| No.        | Variable                        | Dimension  | Loading Factor ( $\lambda$ ) | Loading Factor <sup>2</sup> ( $\lambda^2$ ) | Error (1 - $\lambda^2$ ) | CR           | AVE          |
|------------|---------------------------------|------------|------------------------------|---|--------------------------|--------------|--------------|
| 1          | Internal Control                | LP         | 0.91                         | 0.828                                       | 0.172                    | <b>0.872</b> | <b>0.583</b> |
|            |                                 | PR         | 0.69                         | 0.476                                       | 0.524                    |              |              |
|            |                                 | AP         | 0.56                         | 0.314                                       | 0.686                    |              |              |
|            |                                 | IK         | 0.78                         | 0.608                                       | 0.392                    |              |              |
|            |                                 | PM         | 0.83                         | 0.689                                       | 0.311                    |              |              |
|            |                                 | $\Sigma$   | <b>3.77</b>                  | <b>2.915</b>                                | <b>2.085</b>             |              |              |
|            |                                 | $\Sigma^2$ | <b>14.21</b>                 |   |                          |              |              |
| 2          | Internal Audit                  | IDP        | 0.50                         | 0.250                                       | 0.750                    | <b>0.827</b> | <b>0.553</b> |
|            |                                 | KP         | 0.84                         | 0.706                                       | 0.294                    |              |              |
|            |                                 | LKP        | 0.73                         | 0.533                                       | 0.467                    |              |              |
|            |                                 | PP         | 0.85                         | 0.723                                       | 0.278                    |              |              |
|            |                                 | $\Sigma$   | <b>2.92</b>                  | <b>2.211</b>                                | <b>1.789</b>             |              |              |
|            |                                 | $\Sigma^2$ | <b>8.53</b>                  |   |                          |              |              |
| 3          | Risk-based Audit                | PLN        | 0.77                         | 0.593                                       | 0.407                    | <b>0.809</b> | <b>0.519</b> |
|            |                                 | EAP        | 0.74                         | 0.548                                       | 0.452                    |              |              |
|            |                                 | RPT        | 0.53                         | 0.281                                       | 0.719                    |              |              |
|            |                                 | RM         | 0.81                         | 0.656                                       | 0.344                    |              |              |
|            |                                 | $\Sigma$   | <b>2.85</b>                  | <b>2.078</b>                                | <b>1.923</b>             |              |              |
| $\Sigma^2$ | <b>8.12</b>                     |            |                              |   |                          |              |              |
| 4          | Committee Audit                 | TM         | 0.64                         | 0.410                                       | 0.590                    | <b>0.765</b> | <b>0.523</b> |
|            |                                 | TGJ        | 0.72                         | 0.518                                       | 0.482                    |              |              |
|            |                                 | LK         | 0.80                         | 0.640                                       | 0.360                    |              |              |
|            |                                 | $\Sigma$   | <b>2.16</b>                  | <b>1.568</b>                                | <b>1.432</b>             |              |              |
| $\Sigma^2$ | <b>4.67</b>                     |            |                              |   |                          |              |              |
| 5          | Whistleblowing System           | EWS        | 0.74                         | 0.548                                       | 0.452                    | <b>0.773</b> | <b>0.534</b> |
|            |                                 | CPP        | 0.63                         | 0.397                                       | 0.603                    |              |              |
|            |                                 | MWS        | 0.81                         | 0.656                                       | 0.344                    |              |              |
|            |                                 | $\Sigma$   | <b>2.18</b>                  | <b>1.601</b>                                | <b>1.399</b>             |              |              |
| $\Sigma^2$ | <b>4.75</b>                     |            |                              |   |                          |              |              |
| 6          | Fraud Prevention                | KAF        | 0.52                         | 0.270                                       | 0.730                    | <b>0.801</b> | <b>0.511</b> |
|            |                                 | PPB        | 0.86                         | 0.740                                       | 0.260                    |              |              |
|            |                                 | TP         | 0.64                         | 0.410                                       | 0.590                    |              |              |
|            |                                 | KTK        | 0.79                         | 0.624                                       | 0.376                    |              |              |
|            |                                 | $\Sigma$   | <b>2.81</b>                  | <b>2.044</b>                                | <b>1.956</b>             |              |              |
| $\Sigma^2$ | <b>7.90</b>                     |            |                              |   |                          |              |              |
| 7          | Quality of Financial Statements | RLV        | 0.90                         | 0.810                                       | 0.190                    | <b>0.803</b> | <b>0.514</b> |
|            |                                 | ADL        | 0.64                         | 0.410                                       | 0.590                    |              |              |
|            |                                 | DBD        | 0.73                         | 0.533                                       | 0.467                    |              |              |
|            |                                 | DPH        | 0.55                         | 0.303                                       | 0.698                    |              |              |
|            |                                 | $\Sigma$   | <b>2.82</b>                  | <b>2.055</b>                                | <b>1.945</b>             |              |              |
| $\Sigma^2$ | <b>7.95</b>                     |            |                              |   |                          |              |              |

Source: Processed primary data, 2020



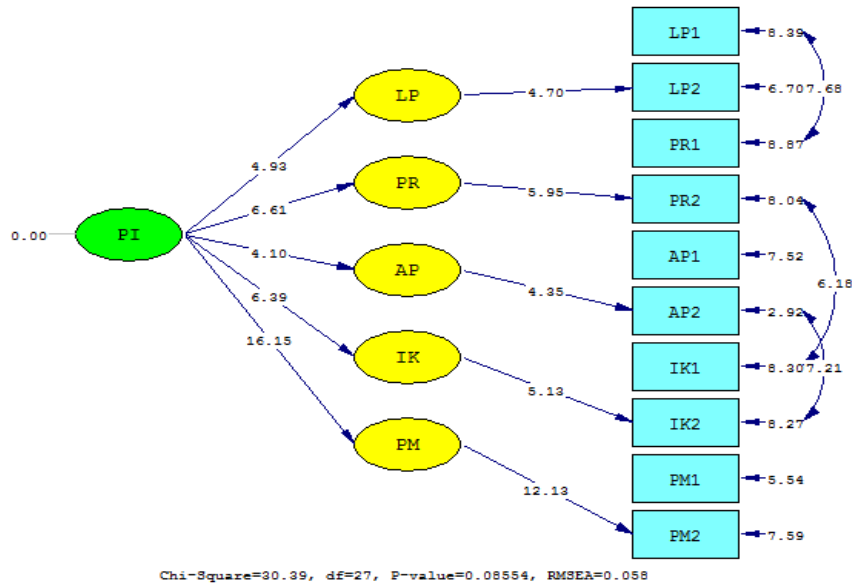

Figure 1 CFA of Internal Control Variable – T-Values

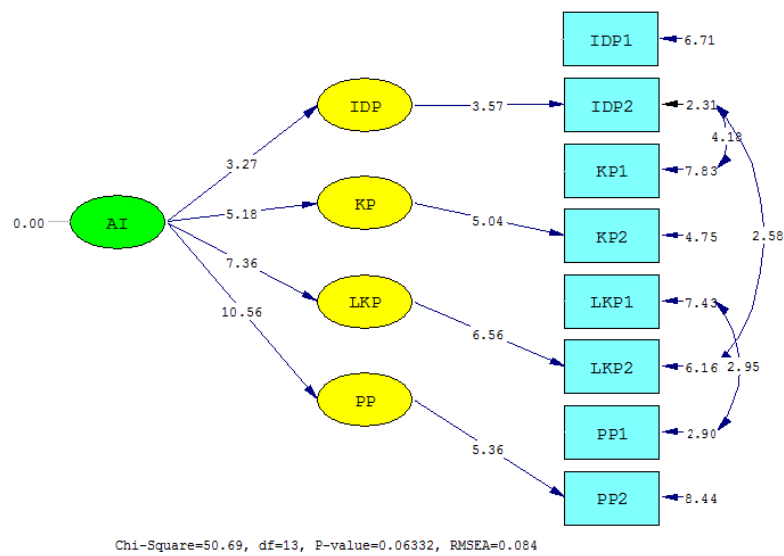

Figure 2 CFA of Internal Audit Variable – T-Values

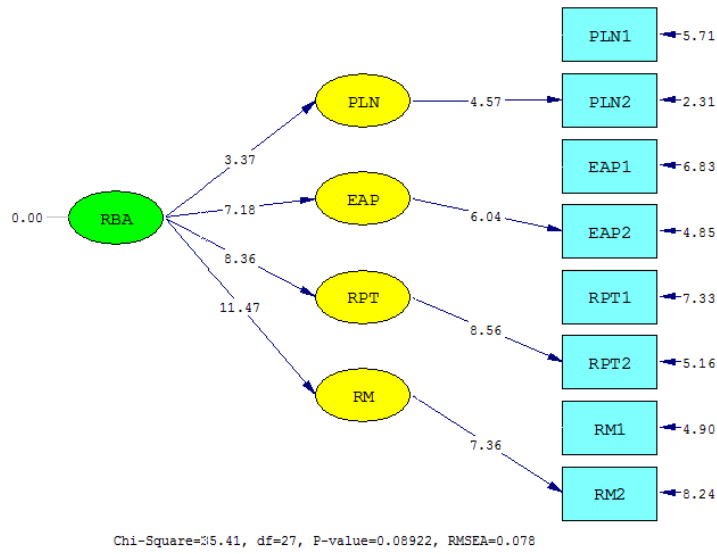

Figure 3 CFA of Risk-Based Audit Variable – T-Values

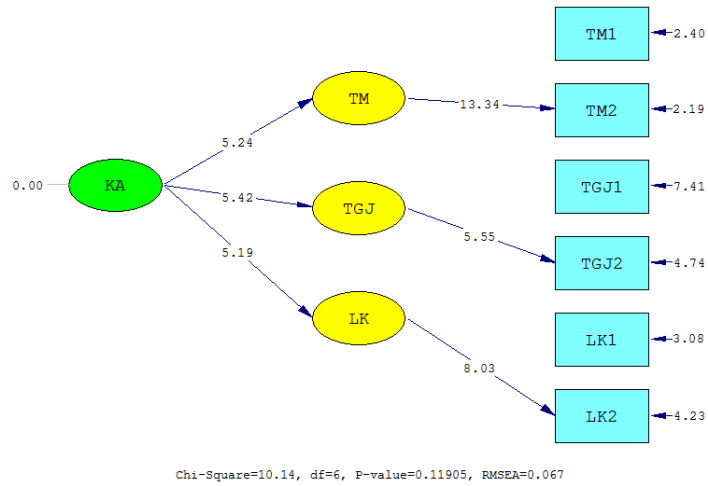

Figure 4 CFA of Audit Committee Variable – T-Values

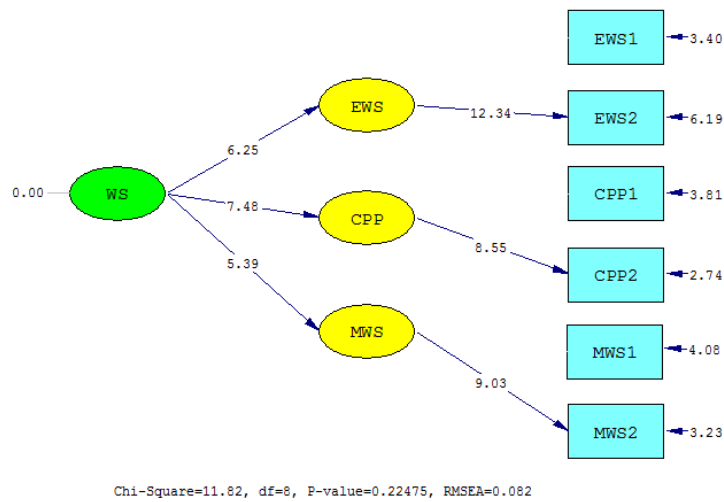

Figure 5 CFA of Whistleblowing System Variable – T-Values

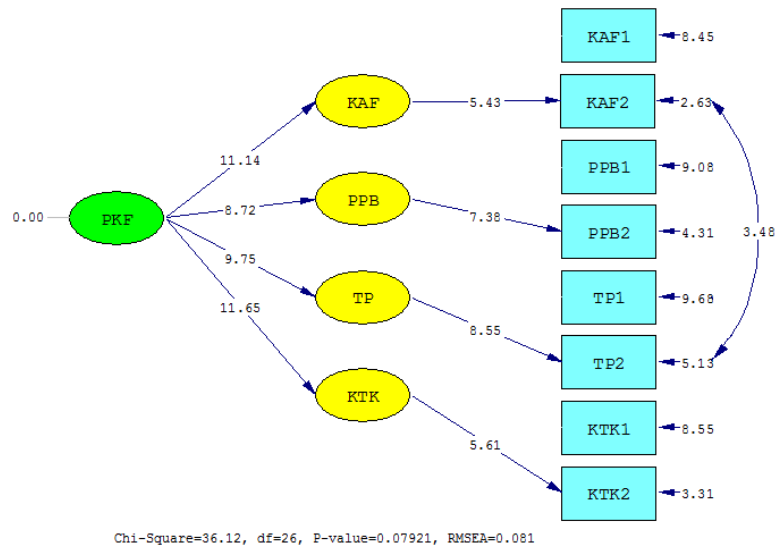

Figure 6 CFA of Fraud Prevention Variable – T-Values

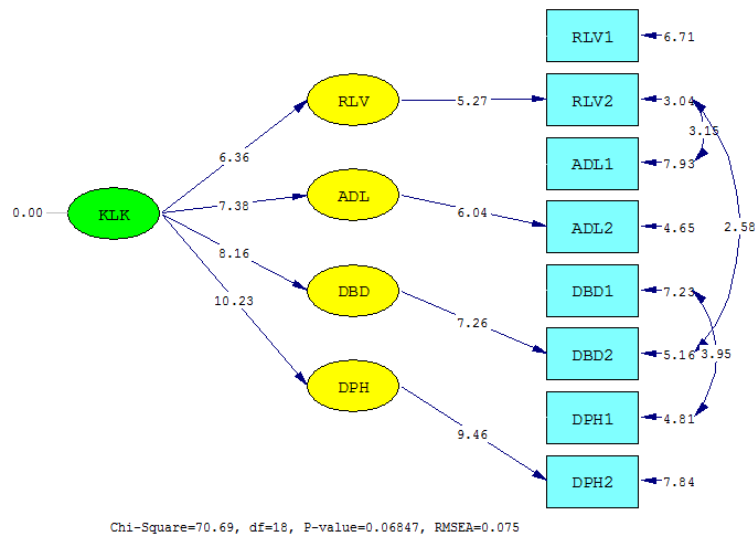

Figure 7 CFA of Quality of Financial Statements Variable – T-Values

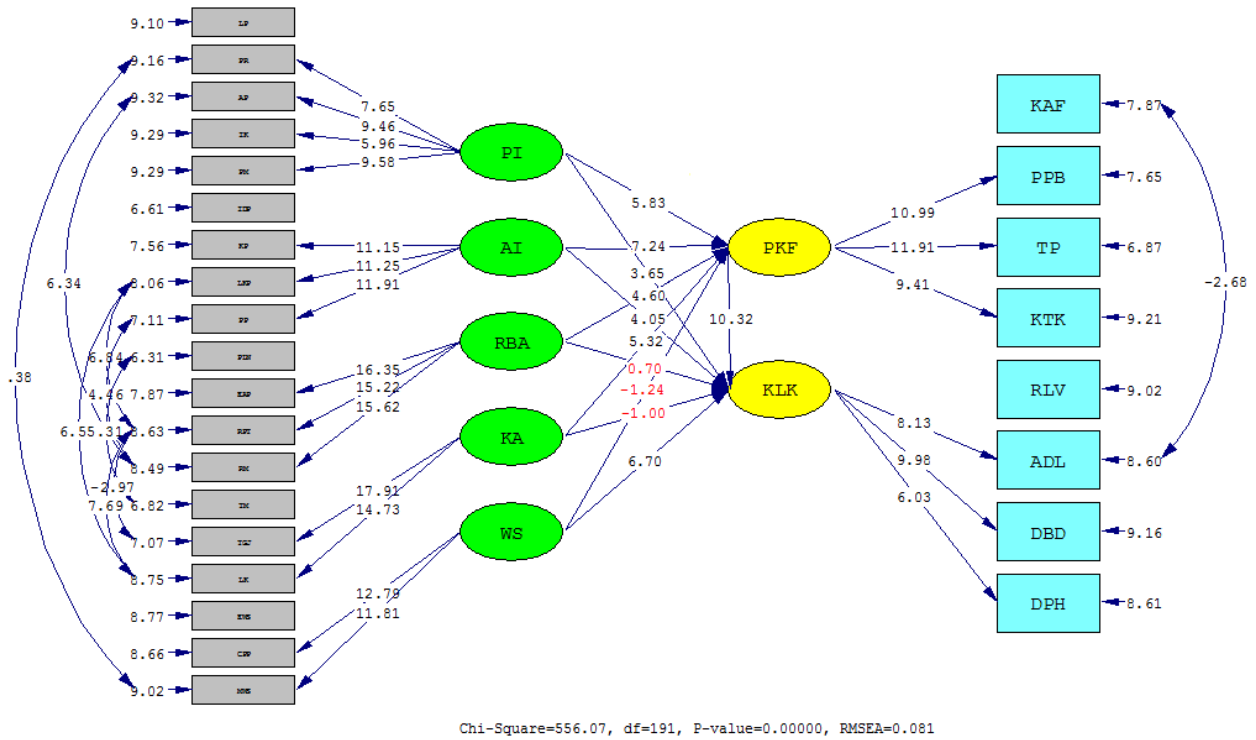

Figure 8 Basic Full Model (Hybrid) Path Diagram in T-Values

Table 6 Goodness of Fit Indices Full Model

| Goodness of Fit      | Cut off Value           | Model Results | Criteria     |
|----------------------|-------------------------|---------------|--------------|
| $\chi^2$ -chi square | $\geq 0,05$             | 0,00          | Poor Fit     |
| RMSEA                | $\leq 0,08$             | 0,081         | Good Fit     |
| NFI                  | $\geq 0,9$              | 0,95          | Good Fit     |
| CFI                  | $\geq 0,9$              | 0,91          | Good Fit     |
| IFI                  | $\geq 0,9$              | 0,91          | Good Fit     |
| RFI                  | $\geq 0,9$              | 0,93          | Good Fit     |
| RMR                  | $\leq 0,05$             | 0,021         | Good Fit     |
| SRMR                 | $\leq 0,05$             | 0,051         | Good Fit     |
| GFI                  | $0,8 \leq GFI \leq 0,9$ | 0,87          | Marginal Fit |
| AGFI                 | $0,8 \leq AGFI < 0,9$   | 0,85          | Marginal Fit |

Source: The results of data processing with Lisrel 8.8

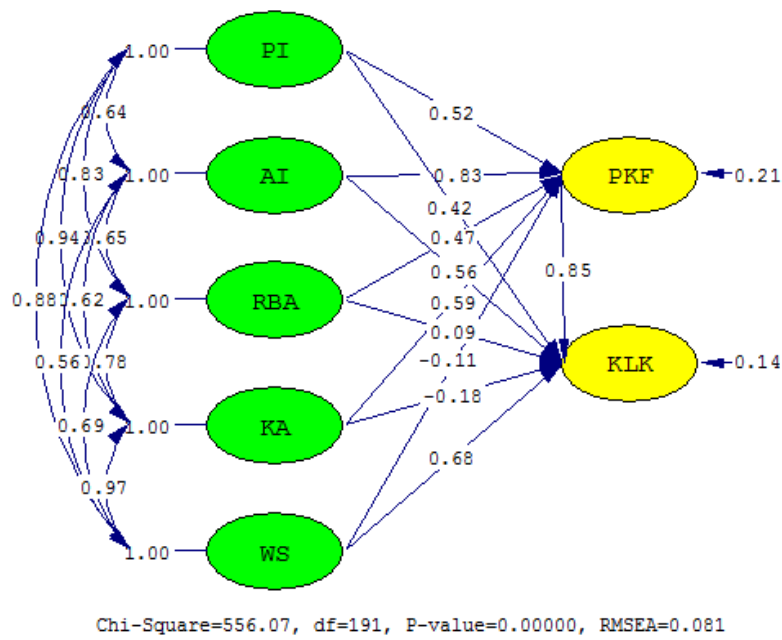

Figure 9 Full Model Structural Path Diagram in Standardized Solution

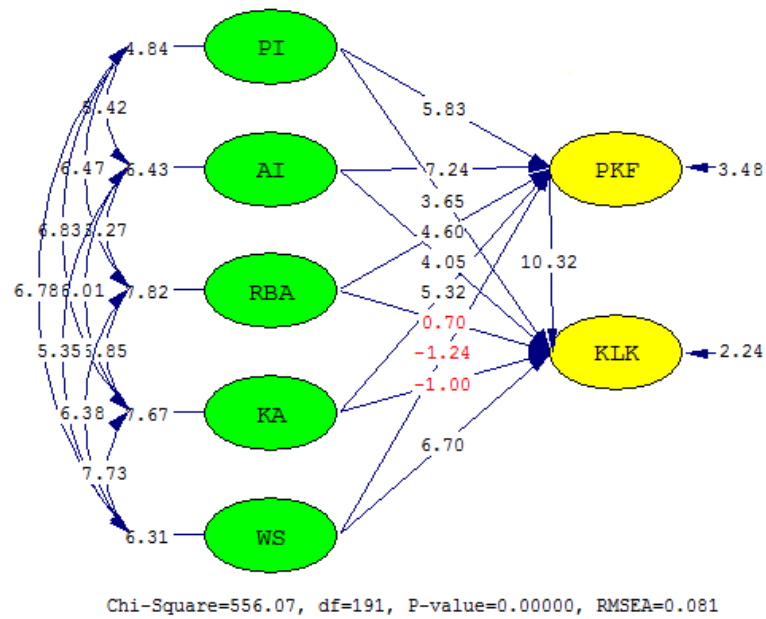

Figure 10 Full Model Structural Path Diagram in T-Values

Table 7 t-Test Results

| Correlation              | Path Coefficient ( $\lambda$ ) | t-count | t-table | Decision  |
|--------------------------|--------------------------------|---------|---------|---|
| H1: $X_1 \rightarrow Y$  | 0,52                           | 5,83    | 1,98    | $t_{\text{count}} > t_{\text{table}}$ ; <b>H1 accepted</b>  |
| H2: $X_2 \rightarrow Y$  | 0,83                           | 7,24    | 1,98    | $t_{\text{count}} > t_{\text{table}}$ ; <b>H2 accepted</b>  |
| H3: $X_3 \rightarrow Y$  | 0,47                           | 4,60    | 1,98    | $t_{\text{count}} > t_{\text{table}}$ ; <b>H3 accepted</b>  |
| H4: $X_4 \rightarrow Y$  | 0,59                           | 5,32    | 1,98    | $t_{\text{count}} > t_{\text{table}}$ ; <b>H4 accepted</b>  |
| H5: $X_5 \rightarrow Y$  | -0,11                          | -1,24   | 1,98    | $t_{\text{count}} < t_{\text{table}}$ ; <b>H5 rejected</b>  |
| H7: $X_1 \rightarrow Z$  | 0,42                           | 3,65    | 1,98    | $t_{\text{count}} > t_{\text{table}}$ ; <b>H7 accepted</b>  |
| H8: $X_2 \rightarrow Z$  | 0,56                           | 4,05    | 1,98    | $t_{\text{count}} > t_{\text{table}}$ ; <b>H8 accepted</b>  |
| H9: $X_3 \rightarrow Z$  | 0,09                           | 0,70    | 1,98    | $t_{\text{count}} < t_{\text{table}}$ ; <b>H9 rejected</b>  |
| H10: $X_4 \rightarrow Z$ | -0,18                          | -1,00   | 1,98    | $t_{\text{count}} < t_{\text{table}}$ ; <b>H10 rejected</b> |
| H11: $X_5 \rightarrow Z$ | 0,68                           | 6,70    | 1,98    | $t_{\text{count}} > t_{\text{table}}$ ; <b>H11 accepted</b> |
| H12: $Y \rightarrow Z$   | 0,85                           | 10,32   | 1,98    | $t_{\text{count}} > t_{\text{table}}$ ; <b>H12 accepted</b> |

Source: The results of data processing with Lisrel 8.8

Table 8 F-Test Results

| Correlation  | Coefficient of Determination | F-count | F-table | Decision  |
|--|------------------------------|---------|---------|---|
| H6: $X_1, X_2, X_3, X_4, X_5 \rightarrow Y$                | 0,79                         | 111,352 | 2,28    | $F_{\text{count}} > F_{\text{table}}$ ; <b>H6 accepted</b>  |
| H13: $X_1, X_2, X_3, X_4, X_5 \rightarrow Y \rightarrow Z$ | 0,86                         | 181,829 | 2,28    | $F_{\text{count}} > F_{\text{table}}$ ; <b>H13 accepted</b> |

Source: The results of data processing with Lisrel 8.8



# SEKOLAH TINGGI ILMU EKONOMI Y.A.I

• Program Pascasarjana Magister Akuntansi (S-2)

• Program Studi Akuntansi (S-1) • Program Studi Manajemen (S-1)

Salemba Raya No. 7-9A Jakarta Pusat, Telp. (021) 3149205, (021) 3914075

Homepage : <http://www.yai.ac.id>; Email : [stie@yai.ac.id](mailto:stie@yai.ac.id)

## **SURAT TUGAS**

No.187/K/STIE Y.A.I/VIII/2020

Sehubungan dengan akan dilaksanakannya penelitian oleh dosen STIE Y.A.I, maka bersama ini Ketua STIE Y.A.I memberikan tugas kepada :

1. Nama : Monika Budiman, SE., M.Ak  
NIDN : 0319049401  
Jabatan : Dosen Tetap Program Studi Akuntansi S1 STIE Y.A.I
2. Nama : Dr. Choirul Anwar, AK., MBA., MAFIS  
NIM : 0004106907  
Jabatan : Dosen Program Studi Akuntansi S1 STIE Y.A.I
3. Nama : Dr. Sudjono, M.Acc  
NIM : 0311025901  
Jabatan : Dosen Program Studi Akuntansi S1 STIE Y.A.I

Untuk membuat penelitian jurnal dengan judul :

**Factors Affecting Fraud Prevention And Its Implication To The Quality Of Financial Statements**

Waktu : September 2020 - Februari 2021

Demikian surat tugas ini dibuat untuk dapat dilaksanakan sebaik-baiknya, atas perhatian dan kerjasamanya diucapkan terimakasih.

Jakarta, 28 Agustus 2020

SEKOLAH TINGGI ILMU EKONOMI Y.A.I,

  
  
**Dr. Reschiwati, SE, MM, Ak, CA**  
Ketua